



**WISDOM
INDUSTRIES, Ltd.**

SAFETY BULLETIN

DATE: FEBRUARY 6, 2006
RIDE: SIZZLER
SUBJECT: SIZZLER LAPBAR MODIFICATION
COMPLIANCE TIME: IMMEDIATE

**RE: INSTALL A SPREADER TUBE & STEP PLATE
IN THE LAPBAR.**

1. Install angle cut tube across lapbar.
2. Trim tube to fit between bent tubes.
3. Weld tube to bent tubes.
4. Weld step plate in center of lapbar opening.
5. Prime and paint tube & plate.
6. Repeat for each lapbar.

**> NOTE: KEEP EACH BAR WITH EACH
SEAT.**

- **WARNING: IF BAR IS REMOVED FROM
SEAT NEW ALL METAL LOCKNUTS MUST
BE USED.**
- **WARNING: CHECK LATCHING OF LAPBAR
ACCORDING TO THE ATTACHED
INSPECTION PROCEDURE.**

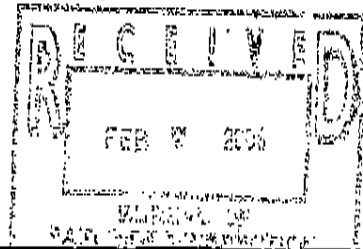

WELD IN TUBE AND STEP PLATE
AS SHOWN

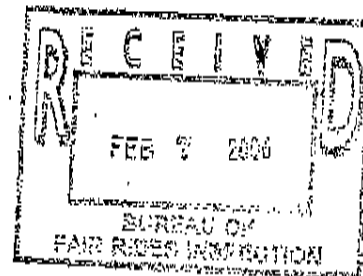
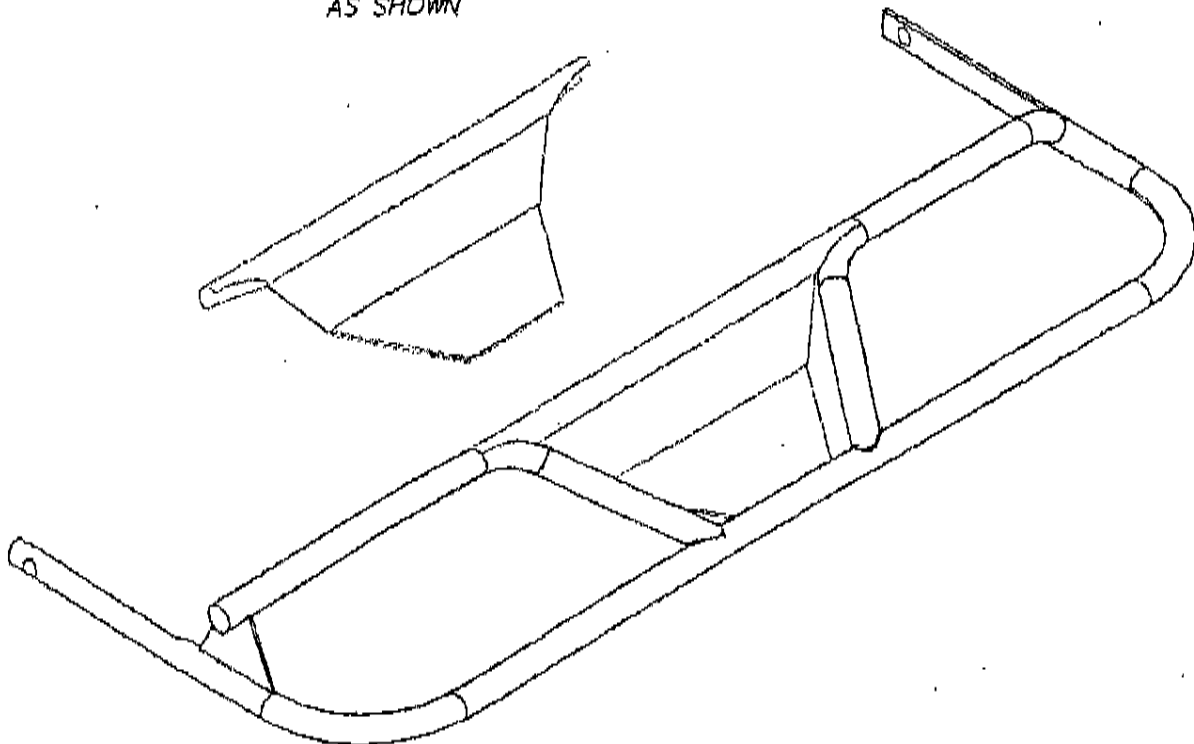

 WISDOM INDUSTRIES Merino, CO 80741	APPROVED BY:		
	DESCRIPTION: HANDLE BAR MODIFICATION	SCALE:	NTS
DRAWN BY: SIZZLER	DATE:	JAN 8 - 06	
	DRAWN BY: M. HOPMAN	DRAWING NUMBER:	FB MOD

**SIZZLER
LAP BAR & SEAT LOCK INSPECTION PROCEDURE**

1. Raise lap bar and latch.
2. Check lap bar hinge bolts and pipe for wear or looseness.
3. Check lap bar arm for cracks.
4. Check that seat lock brass is tight.
5. Open lap bar.
6. Push seat lock pin. It must snap back out and not drag or catch.
7. Close lap bar. Seat lock pin must snap into the notch in the brass.
3/8" minimum engagement of pin in brass.

➤ **NOTE: ELECTRIC SEAT UNLOCKING IS NOT MANDATORY.**

8. Activate electric unlocking system.
NOTE: All seat locks should release.
9. Turn off electric unlocking system.
NOTE: The timer will shut off the solenoids after about 15 seconds.
10. Go around seat to inside (spindle side) and pull on the lap bar sideways and out to try to pop seat lock pin out of the brass.
11. If bar comes open, tie off that car until repairs are made. Replace any components needed if the bar will come open.
12. Repeat for each seat.

****WARNING****

Never install a bolt or knob to manually unlock the lapbar.
Passengers have been known to open the bar while the ride is running and come out of the seat.

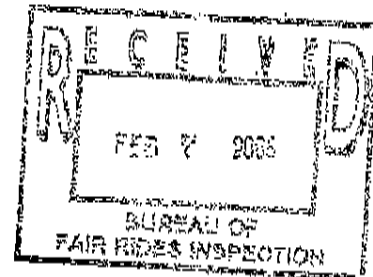

#7

FAX FROM:



F. O. Box 5000
Sterling, Colorado 80751
Telephone: 970-522-7515 or 1-800-634-6097
Fax: 970-522-2902

TO: Allen Harrison St. Florida

Fax # 850-488-9023

RE: Jungle

Number of pages including this page 4

If you did not receive all pages clearly please call Vicor Wisdom

Date Sent 2/7/06

.....
Remarks:

*Jerry forgot a page!
Thanks!*

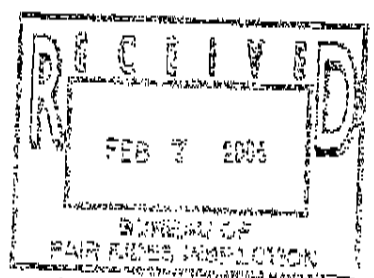

Wisdom Industries, Ltd has 81 years of amusement industry and 28 years of ride manufacturing experience. We have focused this acquired knowledge toward producing attractions that will maximize action, excitement, capacity and profits. Wisdom Industries has been involved and dedicated for over 20 years in amusement industry safety programs across the county including ASTM, AIMS Safety Seminar, NAARSCO, and NW Showmen Seminar.