



**CHANCE RIDES MANUFACTURING, INC.**  
4200 Walker  
Wichita, KS 67277-2328  
U.S.A.  
Phone: 1-316-942-7411 • FAX: 1-316-942-2012  
Website: [www.rides.com](http://www.rides.com)  
E-mail: [rides@rides.com](mailto:rides@rides.com)

Bulletin No:	B402CRM112-0
Release Date:	December 20, 2002
Effective Date:	Immediately
Supersedes:	N/A
Completion Date:	March 20, 2003
Page:	1 of 3

# SERVICE BULLETIN

Ride Manufacturer: CHANCE RIDES, INC.      Affected Production Dates: All

Ride Name: WIPEOUT      Affected Serial Nos.: All Units

Model No.: 402

Abstract of Issue:  
Seat Closeout Kit

**Reason For Release:**

Chance Rides Manufacturing, Inc. has become aware that on the WIPEOUT amusement ride, it is possible for a passenger to extend his/her foot outside the seat. If this happens while the ride is in operation, serious personal injury to the passenger can result.

A seat closeout kit has been developed to help restrain the passengers' feet inside the seat.

**Action to be Taken:**

Chance Rides Manufacturing, Inc. requires that all owner/operators of the above noted WIPEOUT amusement rides install the seat closeout kit within 90 days of the release date of this bulletin. Complete installation instructions are provided on the following pages of this bulletin.

Order and install the Seat Closeout Kit, (part number K402R1264-0). The kit will be offered at a reduced price if ordered within 90 days of the release date of this bulletin.

All work must be performed by qualified personnel, capable of understanding the function of the parts and their proper installation. Use only those components authorized, specified or provided by Chance Rides Manufacturing, Inc. All applicable OSHA safety standards and safe industry practices must be observed.

Observe all safety information contained in the manufacturer's manuals. Make available this bulletin and all related technical information to personnel using the equipment.

Chance Rides Manufacturing, Inc. issues notifications for the benefit of owners of amusement rides manufactured by Chance Rides Manufacturing, Inc. As a service to the industry, and in the interest of employee and public safety, Chance Rides Manufacturing, Inc. also issues notifications for the benefit of owners of amusement ride equipment for which the manufacturer no longer exists, such as the Allan Herschell Company, Chance Manufacturing Co., Inc., Chance Rides, Inc., etc. In doing so, Chance Rides Manufacturing, Inc. does not assume liability for losses associated with amusement ride equipment built by manufacturers other than Chance Rides Manufacturing, Inc.



**CHANCE RIDES MANUFACTURING, INC.**  
4200 Walker  
Wichita, KS 67277-2328  
U.S.A.  
Phone: 1-316-942-7411 • FAX: 1-316-942-2012  
Website: [www.rides.com](http://www.rides.com)  
E-mail: [rides@rides.com](mailto:rides@rides.com)

Bulletin No: B402CRM112-0  
Release Date: December 20, 2002  
Effective Date: Immediately  
Supersedes: N/A  
Completion Date: March 20, 2003  
Page: 2 of 3

Ride Manufacturer: CHANCE RIDES, INC. Affected Production Dates: All

Ride Name: WIPEOUT Affected Serial Nos.: All Units

Model No.: 402

Detail of Issue

**The SEAT CLOSEOUT KIT (part number K402R1264-0) contains the following:**

<u>Part Number</u>	<u>Component</u>	<u>Quantity</u>
402-115-011	SEAT CLOSEOUT - Left Hand .....	10
402-115-013	SEAT CLOSEOUT - Right Hand .....	10
402-115-012	BACKING BAR .....	20
661500000	RIVET - 3/16 x 3/4 Aluminum Dome .....	200

### Installation Instructions

1. Locate each seat closeout in position on the seat. If necessary, trim the seat closeouts as required to fit.

**NOTE:** The seat closeouts are provided as right-hand and left-hand parts.

2. Using the backing bar as a template, drill four 0.219 inch diameter holes in the flange of the closeout to match the backing bar as shown.

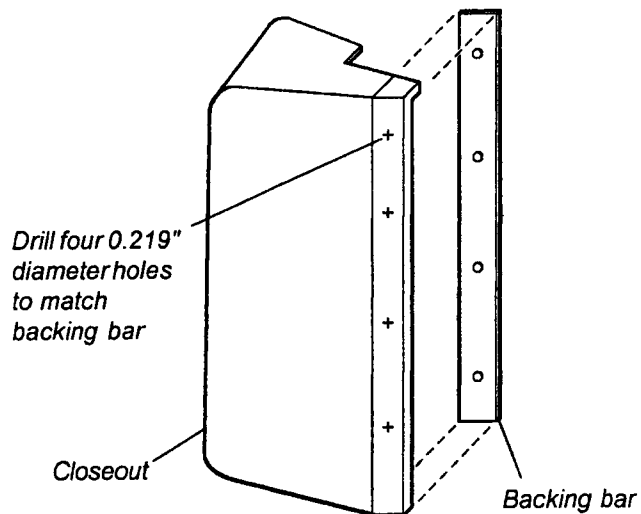



**CHANCE RIDES MANUFACTURING, INC.**  
4200 Walker  
Wichita, KS 67277-2328  
U.S.A.  
Phone: 1-316-942-7411 • FAX: 1-316-942-2012  
Website: [www.rides.com](http://www.rides.com)  
E-mail: [rides@rides.com](mailto:rides@rides.com)

Bulletin No:	B402CRM112-0
Release Date:	December 20, 2002
Effective Date:	Immediately
Supersedes:	N/A
Completion Date:	March 20, 2003
Page:	3 of 3

Ride Manufacturer: CHANCE RIDES, INC.      Affected Production Dates: All

Ride Name: WIPEOUT      Affected Serial Nos.: All Units

Model No.: 402

Detail of Issue (continued):

3. Locate the closeout in position and use it as a template to locate and drill four 0.219 inch diameter holes in the seat. Also, drill six additional holes along the opposite side of the closeout as shown, going through the seat.
4. Insert the backing bar into the seat from the bottom side, aligning the holes in it with the holes in the seat and the closeout.
5. Use the rivets provided to attach the closeout to the seat at 10 places.
6. Repeat the procedure to install all 20 closeouts.

Drill six 0.219" diameter holes  
through closeout and seat

