



NUMBER: B402R1164-0

DATE: AUG. 15, 1994

SUPERSEDES:

SERVICE BULLETIN

Effective Serial Number: All Units

Ride: WIPEOUT

Subject: Turret Drive Inspection

Chance Rides, Inc. has become aware that the socket head cap screws that secure the drive pinion to the bearing keeper for the turret drive of the WIPEOUT amusement ride can loosen. If this occurs, the pinion will become loose and could drop out of position, resulting in damage to mechanical parts.

Chance Rides, Inc. requires all owner/operators of the above noted amusement rides to perform the inspection of the turret drive as outlined in this bulletin.

All work must be performed by qualified personnel, capable of understanding the function of the parts and their proper installation.

NOTICE

Use only those components authorized, specified or provided by Chance Rides, Inc.

Chance Rides Inc. SPECIFICALLY DISCLAIMS ANY LIABILITY for losses associated with any unauthorized alterations and/or modification or additions and installations of unauthorized components.

INSPECTION PROCEDURES:

1. Raise and block boom to give access to the turret drive motor and to stabilize boom while working under it.

WARNING: Heavy items falling or descending out of control can cause injury to personnel. Make sure the boom is adequately secured before attempting to work under it.

2. Remove the five (5) 5/8-11 x 2 1/2 inch hex head cap screws that hold the hydraulic motor in place.

3. Raise the hydraulic motor to gain access to the bearing keeper.

WARNING: Lifting heavy items can cause injury to personnel. Care must be taken when raising the hydraulic motor, which weighs approximately 150 pounds.

Note: The hydraulic lines may need to be removed from the motor in order to raise the motor out of the way.

4. Check the torque (24 - 30 ft. lbs.) of the six (6) socket head cap screws holding the bearing keeper to the pinion.

5. If any of these socket head cap screws are loose, perform the following procedure:

a) remove the socket head cap screws

b) clean the threads

c) apply Blue Loctite 242 to the threads of the socket head cap screws and reinstall using 22 - 27 ft. lbs. of torque

6. Reinstall the hydraulic motor with the five (5) 5/8-11 x 2 inch hex head cap screws and 95 to 115 ft. lbs. of torque.

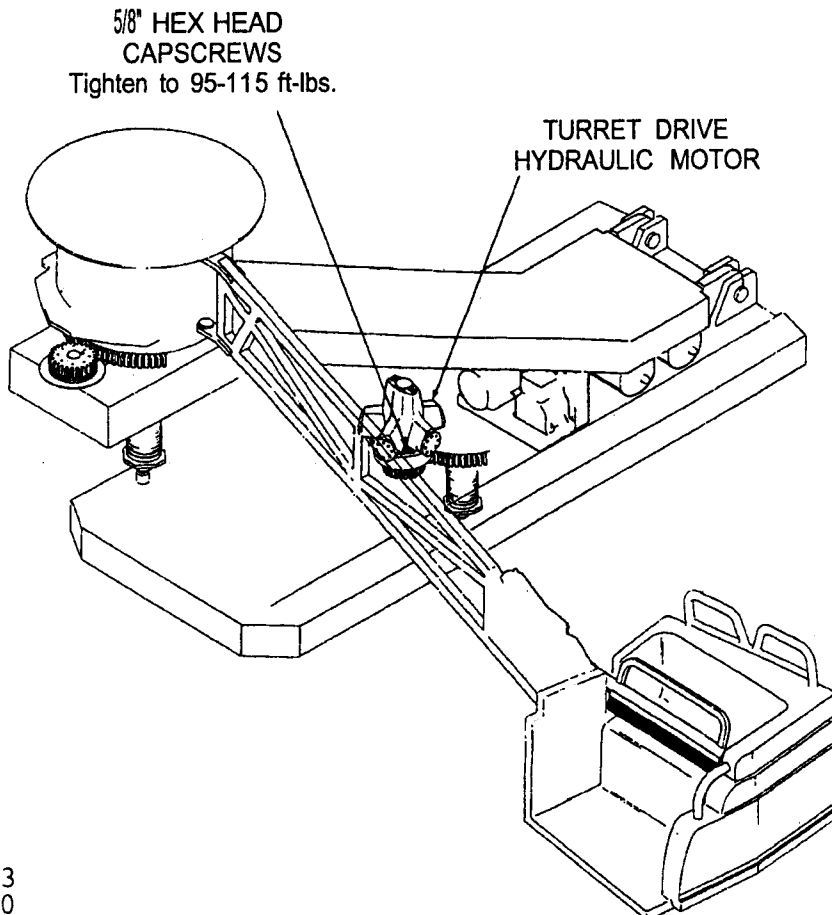

SOCKET HEAD
CAPSCREWS
Apply Loctite 242 Blue
to threads. Tighten to
22-27 ft-lbs.

BEARING KEEPER

