



WISDOM INDUSTRIES, INC.



REQUIRED INSPECTION NOTICE

DATE: AUGUST 1994
RIDE: SIZZLER
SUBJECT: INSPECTION OF SEAT MOUNTING BOLTS

It has been determined by Wisdom Industries that the retaining bolts that fasten the internal car frame on the SIZZLER to the spindle sweep must be checked for tightness on a regular basis. If the fasteners become loose the seat can come loose resulting in possible serious injury to the passengers.

The owners of SIZZLER amusement rides are therefore required to inspect their rides as described in this bulletin. Perform the inspection using the instructions on the enclosed page of this bulletin. Return certificate of compliance within 15 days of the receipt of this bulletin. Inspection must be performed within 1 week.

Immediately check seats for looseness by lifting the rear right side corner of the fiberglass body. If any looseness is noticed do not use that seat until the inspection is performed.

If there are any questions regarding the instructions on this inspection, contact Wisdom Industries.

THE INSPECTION OF THE SIZZLER RIGHT SIDE SEAT INTERNAL FRAME MOUNTING BOLTS.

SIZZLERS WITH THE PLASTIC "S" PANEL OR THE FIBERGLASS COVERS OVER THE SEAT UNLOCKING SOLENOIDS.

1. Remove the "S" panel or the fiberglass cover on the right side of the car.
2. Reach down into the seat and check to see that the two mounting bolts in the frame are tight. If the bolts are loose, broken, or missing remove them and reinstall using Loctite to secure the bolts.
3. If you are unable to reach the bolts through the hole, follow the steps: "FOR SIZZLER THAT DO NOT HAVE "S" PANELS."

FOR SIZZLERS THAT DO NOT HAVE "S" PANELS

1. Remove the two bolts holding the seat lock brass to the side of the car.
2. Slide out the quarter side panel and check the two internal frame mounting bolts for tightness. Replace if they are loose or broken and use Loctite.

FOR INSPECTION OF THE LEFT SIDE SEAT IRON

1. Remove seat liner **OR** cut a hole in the left side of the car body using a hole saw. Review the enclosed drawing for the location of the hole. Using a minimum of a 3" hole saw up to 5" diameter.
3. Locate the hole, drill the hole through the fiberglass and inspect the two mounting bolts. If you would like a cover for this hole. Contact us and we will provide inspection covers for these holes.
4. Check the bolts for looseness, missing bolts or sheared bolts and replace with grade 5-7/16" fine thread bolts and Loctite if needed.

Please notify Wisdom Industries following this inspection and notify us to the status of the bolts on your ride. Following this inspection, please return the enclosed compliance sheet. If you have any questions, please contact Wisdom Industries.

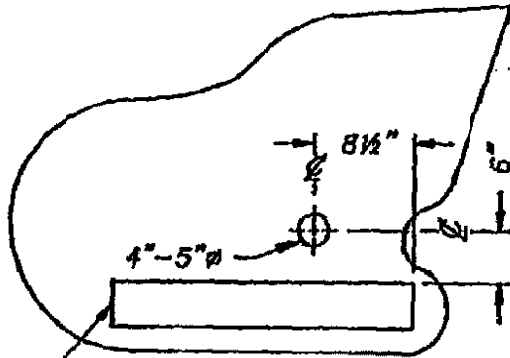

SWEEP CUT OUT

LEFT SIDE OF SEAT

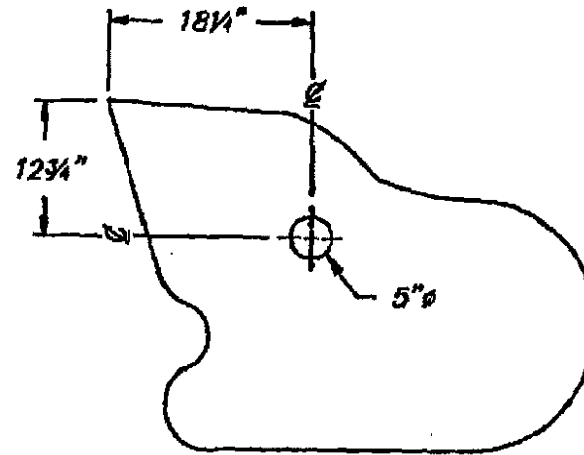

RIGHT SIDE OF SEAT

IF RIGHT SIDE INSPECTION HOLE IS DESIRED.

NOTE: 1 LEVEL TRAILER.

2 USE LEVEL FROM BACK CORNER OF SEAT TO MARK CENTER LOCATION.

 WISDOM INDUSTRIES		Merino, CO 80741
SCALE: N.T.S.	APPROVED BY:	DRAWN BY: MFK
DATE: 08-25-94		REVISED:
DESCRIPTION		
SEAT INSPECTION HOLE LOCATIONS		
EQUIPMENT:		DRAWING NUMBER
SIZZLER		SEAT