

465.

Zierer Tivoli Coaster service bulletin

Zierer has issued a service bulletin pertaining to its Tivoli Coasters and specific serial numbers of these devices and/or ride types. The bulletin specifies individually the necessary maintenance intervals for the tracks and supports on such devices as a precautionary measure, in particular noting the age of the rides and the number of years in operation.

The information contained within is that of the manufacturer and not NAFLIC. When following the advice from the manufacturer, you are reminded of your duties and responsibilities under HSG175 regarding modifications.

Committee Members: Mr. D Dadswell (Chairman), Mr. A Mellor (Secretary), Mr. P Smith, Mr. J Green,
Mr. D Cox, Mr. I Davies, Mr. J Shilling, Mr. D Inman & Mr. R Hiscoe

www.naffic.co.uk

Supported By:



* Noted



ZIERER Karussell- und Spezialmaschinenbau GmbH & Co. KG
Josef-Wallner-Str. 5, D-94469 Deggendorf

Karussell- und Spezial-
maschinenbau GmbH & Co. KG

Head office:
Josef-Wallner-Straße 5
94469 Deggendorf

Phone:
(+49) 991 9106 0 Switchboard
(+49) 991 9106 38 Service

Fax:
(+49) 991 9106 83 Service
(+49) 991 9106 24 Engineering

E-Mail: service@zierer.com
Internet: www.zierer.com

Service Bulletin

Zierer Bulletin #	Revision:	Pages	System	Description:	Date:	Issued:
SB-TC-1002	0	4	Tivoli Coaster	Service Bulletin	02.06.2015	wmt
Original Ride Manufacturer			Release Date	Affected Production Dates:	Ride Name:	
ZIERER – Karussell und Spezialmaschinenbau			08.06.2015		Tivoli Coaster	

1. Affected Serial Nos. and/or Ride Type:

Tivoli Coaster (I-Track with custom made design) - Serial no.:

8505001, 8506001, 8507001, 8509001, 8510001, 8512001, 8513001, 8513002, 8514001, 8515001, 8516001, 8517001, 8517004, 8518001, 8518002, 8519001, 8519002, 8523001, 8154001, 8173001, 8181001, 8182001, 8183001, 8187001

2. Reason for release:

In regard to the impressive age of your I-track roller coaster and the many operative years of the above-mentioned facilities, we have individually specified the necessary maintenance intervals for the tracks and the supports. This precautionary measure shall provide also in future for the safe operation of your ride.

3. Visual inspection:

3.1. Track to Track Connections

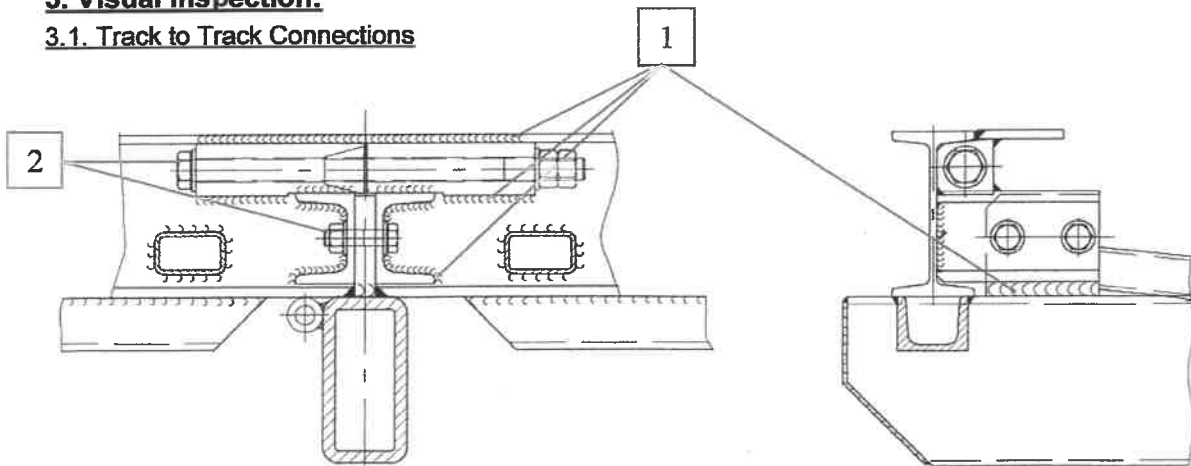

- ➔ Pos.1 – Visual check for cracks at welding seams (weekly insp. cycle of 20% of always different connections)
- ➔ Pos.2 – General visual check at bolts (weekly insp. cycle of 20% of always different connections)

In case of indications, a check of 100% will be required!

Zierer Bulletin #	Revision:	Page	System	Description:	Date:	Issued:
SB-TC-1002	0	1 of 4	Tivoli Coaster	Service Bulletin	02.06.2015	wmt

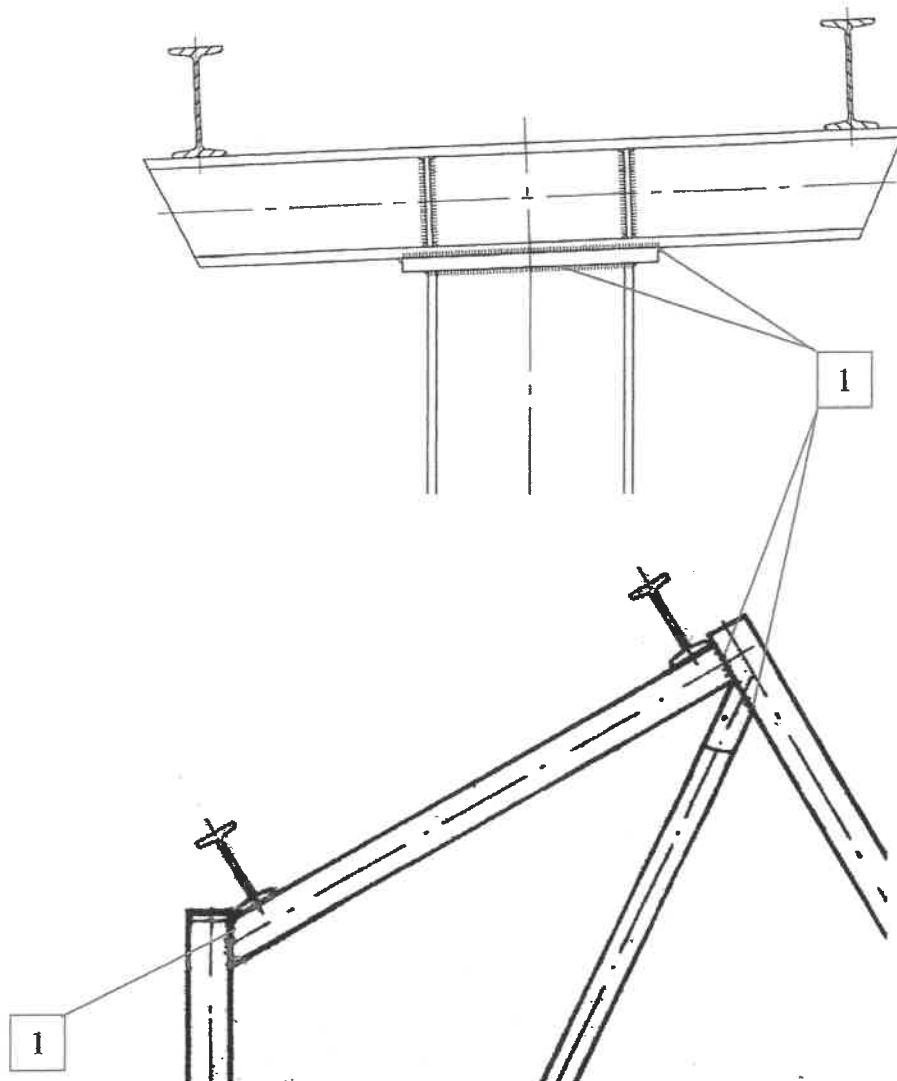
3.2. Columns

→ Pos.1 – Visual check for cracks at welding seams (weekly insp. cycle of 20% of always different connections)

In case of indications, a 100% check will be required!

Zierer Bulletin #	Revision:	Page	System	Description:	Date:	Issued:
SB-TC-1002	0	2 of 4	Tivoli Coaster	Service Bulletin	02.06.2015	wmt

3.3. Car to car connections (supplemental check for safe operation)

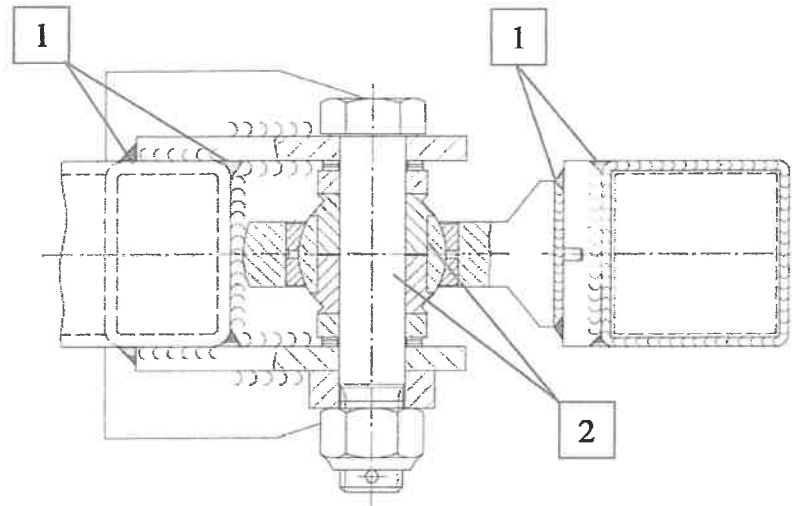

- ➔ Pos.1 – Visual check for cracks at welding seams (daily)
- ➔ Pos.2 – General visual check at bolts and bearings (daily)

In case of indications, a check of 100% will be required!

4. Lead-in groove at I-Track (caused by running wheel):

4.1 Medium Tivoli Coaster

	Track Section	Measure X
	Train Station	3 mm
	Lift uphill	2 mm
	Lift downhill	2 mm
	Curves	1 mm
	Straight Sections	2 mm
<p>Note: This is the absolute wear limit regarding lead in-groove of the I-Track. Do not exceed the values specified above. If wear limit should already be reached, please contact ZIERER After Sales.</p>		



5. Contact

For questions please contact:

ZIERER Karussell- und Spezialmaschinenbau GmbH & Co. KG

Josef-Wallner-Strasse 5
D-94469 Deggendorf

Mr. Martin Weinberger

Phone: (+49) 991 9106 55

Fax: (+49) 991 9106 83

E-Mail: m.weinberger@zierer.com

Internet: www.zierer.com

Zierer Bulletin #	Revision:	Page	System	Description:	Date:	Issued:
SB-TC-1002	0	4 of 4	Tivoli Coaster	Service Bulletin	02.05.2015	wmt